

Model 143-80-6

Domestic Service Regulator with Low Pressure Cut-Off



Technical Data

Valve Body	Cast Iron - 125 psig working pressure
Spring and Lower Case	Die-Cast Aluminum
Orifice	Aluminum
Fulcrum Pin	Stainless Steel
Valve Seat	One piece Buna-N
Valve Stem	Fiberglass reinforced nylon
Throat/Support/Stem Guide	Cast Aluminum integral to the lower case.
Diaphragm Plate	Plated Steel
Diaphragm	Nylon fabric-reinforced Buna-N
Vent and Valve	Polyethylene valve and seat 3/4" or standard 1" NPT
Operating Temperature	-20° to +150° F (-28.9° to +65.5° C)
Corrosion Protection	Cases dip primed chromate conversion coating, enamel topcoat
Internal Relief Valve	Set to relieve at approximately 7-10" w.c. above normal outlet pressure setting

Dimensions

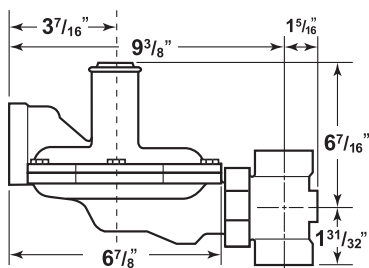

Valve Body Sizes

Straight

3/4" x 3/4"

3/4" x 1"

1" x 1"

1" x 1-1/4"

1-1/4" x 1-1/4"

Mounting Positions

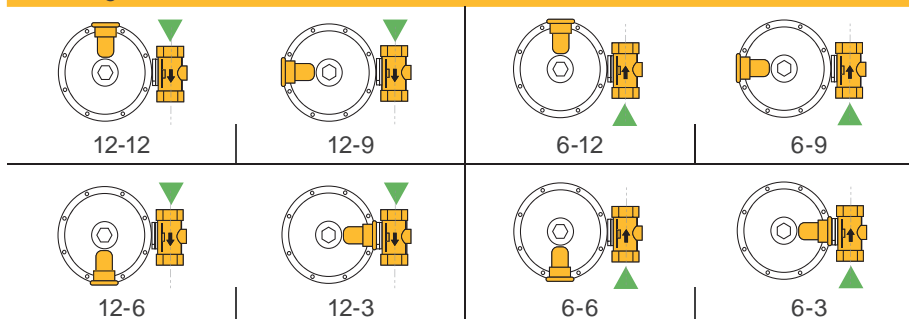

Orifice and Maximum Inlet Pressure

Pressure	Size	Part Number
60 psig	1/4"	143-62-023-49
40 psig	5/16"	143-62-023-51
25 psig	3/8"	143-62-023-52
15 psig	7/16"	143-62-023-53

Regulator Spring Chart

Normal Range	Color	Part Number
4-1/2" - 7-1/2" w.c.	Red	143-62-021-15
6" - 9-1/2" w.c.	Blue	143-62-021-16
7-1/2" - 15" w.c.	Green	143-62-021-17
13-1/2" - 29" w.c.	Orange	143-62-021-18

Typical Performance Curve

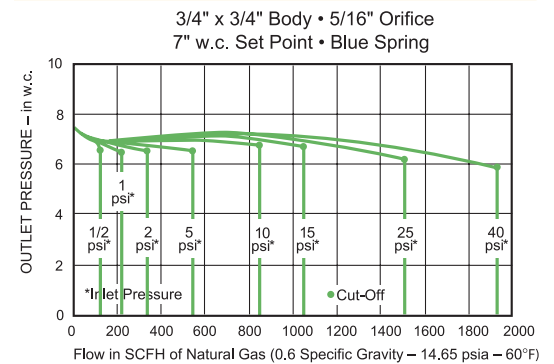

Internal Relief Valve

Lever blocked with valve disc in the wide open position
7" w.c. Set Point - Blue Spring • 1" Vent - No Vent Piping

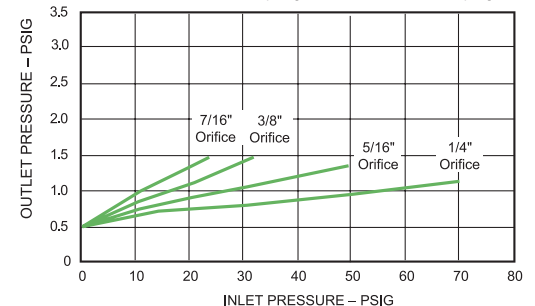

Note:

For outdoor installations, it is recommended that the regulator be installed so that the regulator vent faces downward to avoid the potential for water and other foreign matter entering the regulator and interfering with the proper operation of the regulator.

All products purchased and services performed are subject to Sensus' terms of sale, available at either; <http://na.sensus.com/TC/TermsConditions.pdf> or 1-800-METER-IT. Sensus reserves the right to modify these terms and conditions in its own discretion without notice to the customer.

This document is for informational purposes only, and SENSUS MAKES NO EXPRESS WARRANTIES IN THIS DOCUMENT. FURTHERMORE, THERE ARE NO IMPLIED WARRANTIES, INCLUDING WITHOUT LIMITATION, WARRANTIES AS TO FITNESS FOR A PARTICULAR PURPOSE AND MERCHANTABILITY. ANY USE OF THE PRODUCTS THAT IS NOT SPECIFICALLY PERMITTED HEREIN IS PROHIBITED.

Model 143-80-6

Service Regulator with Low Pressure Cut-Off

Capacities

SCFH Natural Gas (0.6 specific gravity - 14.65 psia - 60° F)

Pipe Size: 3/4 x 3/4" (Red or Blue Spring)

Inlet Psig	Orifice			
	1/4"	5/16"	3/8"	7/16"
1/2	-	90	180	240
1	100	200	300	400
2	140	300	420	580
5	230	600	750	800
10	380	740	990	1050
15	460	950	1050	1140
25	640	1100	1100	-
40	870	1300	-	-
60	1160	-	-	-

(Green Spring)

Orifice			
1/4"	5/16"	3/8"	7/16"
-	90	120	140
90	160	200	250
140	240	320	370
220	460	530	580
370	700	720	780
480	800	860	920
660	1000	900	-
910	1300	-	-
1160	-	-	-

Pipe Size: 3/4 x 1"; 1" x 1" (Red or Blue Spring)

Inlet Psig	Orifice			
	1/4"	5/16"	3/8"	7/16"
1/2	-	90	210	270
1	100	210	310	430
2	140	300	420	650
5	230	610	750	1100
10	380	760	1120	1300
20	460	960	1300	1300
25	640	1300	1300	-
40	870	1300	-	-
60	1160	-	-	-

(Green Spring)

Orifice			
1/4"	5/16"	3/8"	7/16"
-	90	120	160
90	160	230	260
140	240	350	410
220	460	730	800
370	700	1090	1220
480	800	1300	1300
660	1000	1300	-
910	1300	-	-
1160	-	-	-

Pipe Size: 3/4 x 1"; 1" x 1" (Red or Blue Spring)

Inlet Psig	Orifice			
	1/4"	5/16"	3/8"	7/16"
1/2	-	90	210	270
1	100	210	310	430
2	140	300	420	650
5	230	510	750	1100
10	380	760	1120	1300
20	460	960	1300	1300
25	640	1300	1300	-
40	870	1300	-	-
60	1160	-	-	-

(Green Spring)

Orifice			
1/4"	5/16"	3/8"	7/16"
-	90	120	160
90	160	230	260
140	270	350	430
220	470	730	870
370	740	1090	1300
480	930	1300	1300
660	1160	1300	-
910	1300	-	-
1160	-	-	-

NOTES:

Orifice Outlet Pressure variations:

- Red Spring 4-1/2" to 7-1/2" w.c.
- Blue Spring 6" to 9-1/2" w.c.
- Green Spring 7-1/2" - 15" w.c.

Figures highlighted in each column indicate maximum capacity for each orifice at recommended pressure within the optimum performance range.

This performance data is based on normal testing at 70° F flowing temperature. Changes in performance can occur at extreme low flowing temperatures.

Maximum Emergency Pressure under normal operating conditions without damaging the regulator:

- Low pressure inlets = Stated Max. Inlet Pressure + 10 psi.
- Diaphragm case = Set Point + 3 psi.

If the outlet pressure exceeds this pressure, the regulator must be removed from service and carefully inspected. Damaged or otherwise unsatisfactory parts must be replaced before returning the regulator to service. The maximum outlet pressure safely contained in the diaphragm case is 10 psi. (Safely means no leakage as well as no bursting.)

Calculations for Other Gases

Type	Sp. Gravity	Corr. Factor
Air	1.00	0.77
Propane	1.53	0.63
1350 BTU Propane/Air	1.20	0.71
Nitrogen	0.97	0.79
Dry Carbon Dioxide	1.52	0.63

For other non-corrosive gases $\sqrt{\frac{0.60}{\text{Specific Gravity of the Gas}}}$

Full Open Capacity Calculations

Formula 1: For $\frac{P_1}{P_0}$ **less than** 1.894)

$$Q = K \sqrt{P_0(P_1 - P_0)}$$

Formula 2: For $\frac{P_1}{P_0}$ **greater than** 1.894)

$$Q = \frac{KP_1}{2}$$

Where:

Q = max. capacity of regulator (in SCFH of 0.6 specific gravity natural gas)

K = the regulator constant from the table below (orifice with low pressure cut-off stem inside)

5/8"	1/2"	3/8"	5/16"	1/4"	3/16"	1/8"
820	520	292	206	132	74	33

P₁ = absolute inlet pressure (psia)

P₂ = absolute outlet pressure (psia)