



Sonix 2000 Installation & Maintenance Manual

Table Of Contents

DESCRIPTION	3
APPLICATION	3
INTRINSIC SAFETY	4
CLEANING.....	4
COMMUNICATION WITH THE METER	4
INSTALLATION.....	6
UNPACKING AND DISPLAY CHECK	6
METER CONNECTION AND ORIENTATION	7
NEGATIVE FLOW.....	7
REMOVING THE FRONT COVER.....	8
REFITTING THE FRONT COVER	8
POSITIONING THE DISPLAY AND VENT PLUGS	9
POSITIONING THE DISPLAY	9
POSITIONING THE VENT PLUGS.....	9
CONNECTING THE OPTICAL READING HEAD.....	10
EEPROM HARDWARE LOCK.....	10
PULSE OUTPUTS.....	11
MAINTENANCE.....	12
BATTERY REPLACEMENT	12
REPLACING LCD	13
REPLACING THE PULSE BOARD.....	15

Description

Sonix 2000 ultrasonic meter is an inferential gas meter that utilizes the time-of-flight technique to measure the consumption of natural gas.



As standard the Sonix 2000 is supplied with twin pulse outputs, Charles law temperature correction, fixed pressure correction and 60 day data logging.

The Sonix 2000 can also be supplied as a corrector version incorporating live pressure measurement. **Refer to the Sonix 2000 corrector manual for installation of this version.**

Application

Sonix meters should only be used with clean, dry natural gas or air. The table below provides information on rated capacity with a 0.5" w.c. (1.25 mbar) pressure loss, using 0.6 specific gravity natural gas.

Meter	Q _{max}	MAOP	Q _{max}	MAOP
Sonix 2000	2000 cfh	60 psi	57 m3h	4 mbar

The maximum allowable operating pressure (MAOP) should never be exceeded as internal damage to the ultrasound transducers may occur.

The Sonix 2000 is suitable for use in an operating temperature range of -30 °F to +130 °F (-35 °C to +55 °C).

Intrinsic Safety

THE SONIX 2000 IS SUITABLE FOR USE IN CLASS 1, DIVISION 2, GROUP D OR NON-HAZARDOUS LOCATIONS ONLY. Ref:- CSA C22.2 No. 213-M1987

The meter electronics are enclosed in a vented aluminum case which provides both weather (NEMA 4X) and EMC protection.

Repair of the electronics is not permitted other than as described in this manual for the replacement of the pulse output board and the LCD display. Should the meter electronics develop a fault, in the first instance please contact Sensus Metering System's technical support group.

Only SUITABLE non-incendive inputs are to be connected to the field-wiring terminals via the PULSE cable.

In service maintenance as described in this manual must only be done in dry and clean conditions and in a NON-Hazardous Zone.

Do not remove any screws or fasteners other than those described in this manual.

Cleaning

The meter may be cleaned using a soft cloth and soapy water. It is not possible to clean the internal measuring elements of a meter removed from an installation.

Do not use solvents to clean the meter or display.

WARNING – STATIC RISK – DO NOT RUB OR CLEAN THE PLASTIC DISPLAY COMPONENTS IN A HAZARDOUS AREA AS A SPARK MIGHT BE GENERATED.

Communication with the Meter

The meter is provided with a optical reading port for use with the SonixCom PC program. Refer to the section **Connecting the Optical Reading Head**.

Refer to the SonixCom manual supplied with the program for detailed instruction on meter set up, data down load and maintenance procedures.

LINE DRAWING SONIX 2000

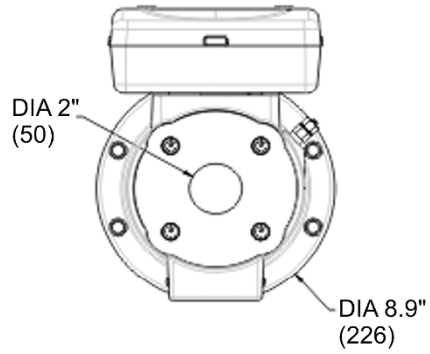
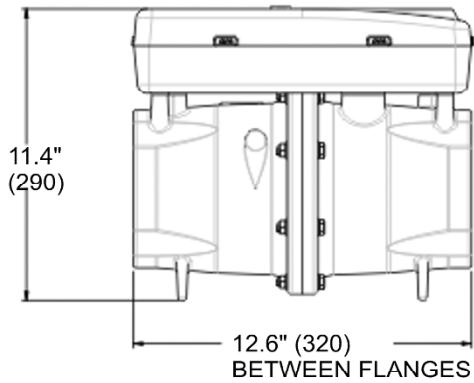
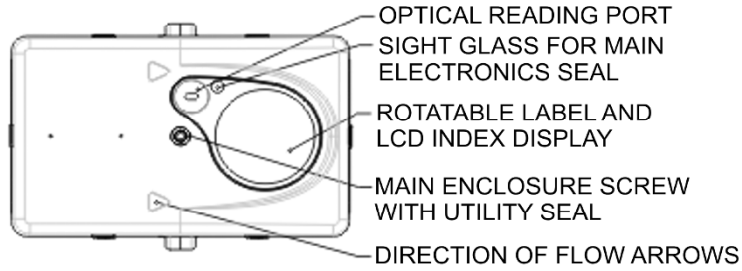

VENTS AND BLANKS TO BE POSITIONED DURING INSTALLATION

PETE'S PLUG

REMOVABLE COVER FOR BATTERY AND FITTED OPTIONS ACCESS

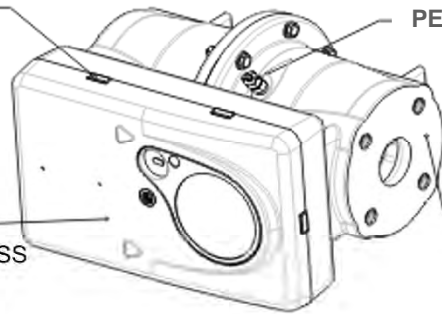

FLANGE AS ANSI B16.5 2" 4 HOLES 5/8x11 UNC 15/16" DEEP ON 4.5" PCD

Installation

Unpacking and Display check

Carefully unpack the Sonix meter and make sure that there is no obvious damage. Make sure that the LCD is functioning and displays 999999 as shown below. If the LCD is not operating, go to the replacement of battery section. If a new battery is connected and the LCD is still not functioning please contact Sensus Metering System's technical support group.

The LCD rolls over after a limited amount of gas runs through the meter (10 cubic feet, or 1 cubic meter). When the display rolls over to Zeros, all flags will be cleared and the diagnostics reset.

The three smaller digits indicate 10,1,and 1/10 cfh of volume in imperial mode or litres in metric mode.

If any diagnostic flags are set by the meter the display of the smaller digits will alternatively switch every 8 seconds between the volume display and the flag.



A segment check occurs once every minute. When the LCD is going through the segment check, all segments are energized (light up) as indicated below.

If segments fail to display please contact Sensus Metering System's technical support group.



Meter connection and orientation

Refer to the **line drawing** for bolt sizes and the distance between mounting flanges.

Examine the label data to make sure that the meter specifications match the application on which it will be used (capacity required and maximum allowable operating pressure).

Sonix meter accuracy is not affected by installation orientation (unlike diaphragm and rotary meters). There are no requirements for the sets to be level, meters can be installed in any orientation providing the display face is in the vertical plane.

Important note: To ensure correct venting of the electronics enclosure the meter must always be installed with the display vertical. (also see Positioning the Display and Vent Plugs)

If the meter is installed where there is a possibility of condensates forming in the gas flow then it is recommended that the installation should be orientated with the meter body horizontal and with the flow from left to right.

Make sure that the meter is not subjected to undue mechanical stresses, or located where it could be subject to attack by aggressive chemicals. Sonix meters are not designed for use in environments where flammable dusts may constitute a hazard.

The Sonix range of meters will not lock up or be damaged by over ranged flows. There is no need to install by-pass piping, filters and strainers, or over-speed protection.

The Sonix meter accuracy is not affected by upstream flow disturbance so lengths of straight piping are not required.

The meter should be pressurized and depressurized slowly to avoid damage to the ultrasonic transducers. Generally the pressure gradient should not exceed 5psi (34.5kPa) per second.

Negative Flow

Refer to the SonixCom manual supplied with the Sonixcom program for detailed instruction and description of diagnostic Flags.

Negative flow will cause a “b” flag to be generated.

When reverse flow is detected, the corrected and uncorrected volume registers will not increment or decrement. Any volume will be stored in the reverse flow register.

In order for the negative flow register to be activated, the negative flow limit of -9.5 cfh (-267 l/h) must be exceeded and the flow must be measured for longer than 8.5 minutes.

When the reverse flow limit is surpassed the diagnostic flag appears at midnight.

Removing the Front Cover

The removal of the front cover in service must only be done in dry and clean conditions and in a NON-Hazardous Zone.

1. If fitted, use a flat blade screwdriver (or a Rockseal removal tool) to break the tamper obvious Rockseal in the center of the front cover. The seal can then be pried out with the screwdriver blade.
2. After the Rockseal is removed, use a 5mm long series hexagon wrench (Allen key) to undo the cover retaining screw until the front cover can be lifted away from the meter.

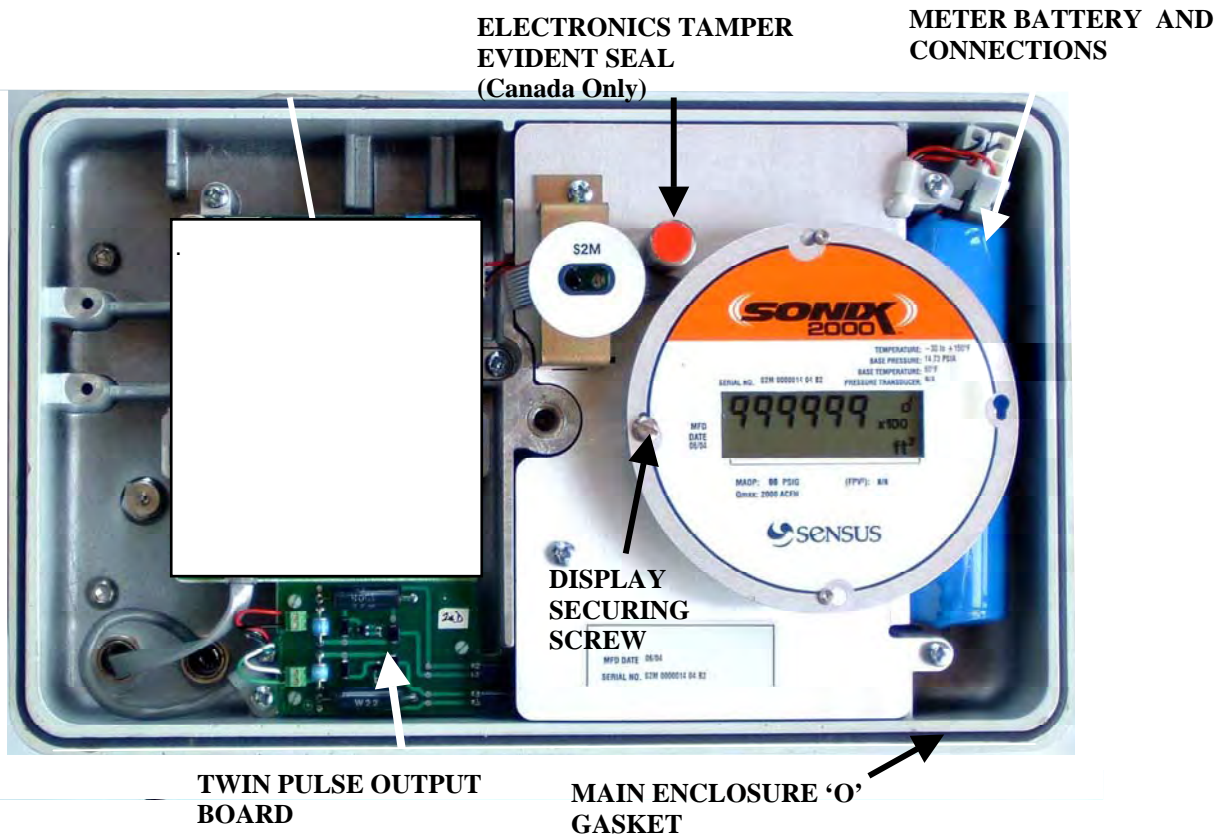

Refitting the Front Cover

1. Ensure that the vent plugs and gaskets are in place in the front cover and that the main enclosure 'O' gasket is in position and undamaged.
2. Wipe the mating faces clean on both the enclosure and front cover and ensure any wires will not be trapped.
3. Re-fit the cover tightening the retaining screw fully. Fit a new the tamper evident seal.

NOTE: If you do not re-install the tamper obvious seal, the front cover can be easily removed.

Positioning the Display and Vent Plugs

It is possible to rotate the display assembly to one of four orientations to suit the meter installation. It is also important that the vents are positioned to suit the installation orientation.

Each Sonix 2000 meter is supplied with a set of 7 vent plugs, 2 of which are vented with a pattern of holes through, the remaining 5 have the holes blanked.

Positioning the Display

1. Remove the cover as section **Removing the Front Cover**.
2. Remove the display securing screw which secures the display.
3. Rotate the display slightly to unlatch from the retaining posts.
4. Reposition the display in the desired orientation and secure by replacing the screw.

Positioning the Vent Plugs

It is essential that vent plugs are positioned in the cover so that blanked plugs are in the upper and side walls of the enclosure. Vent plugs with holes are **only** fitted in the face pointing down to provide a drain for the enclosure. Two vents with holes will be required if either of the longer sides of the enclosure are facing towards the bottom.

1. Push the plugs into position ensuring that sealing edges are not folded under and are flat to the outer face of the cover and that the bottom face is flush or just proud to the cover sealing face.

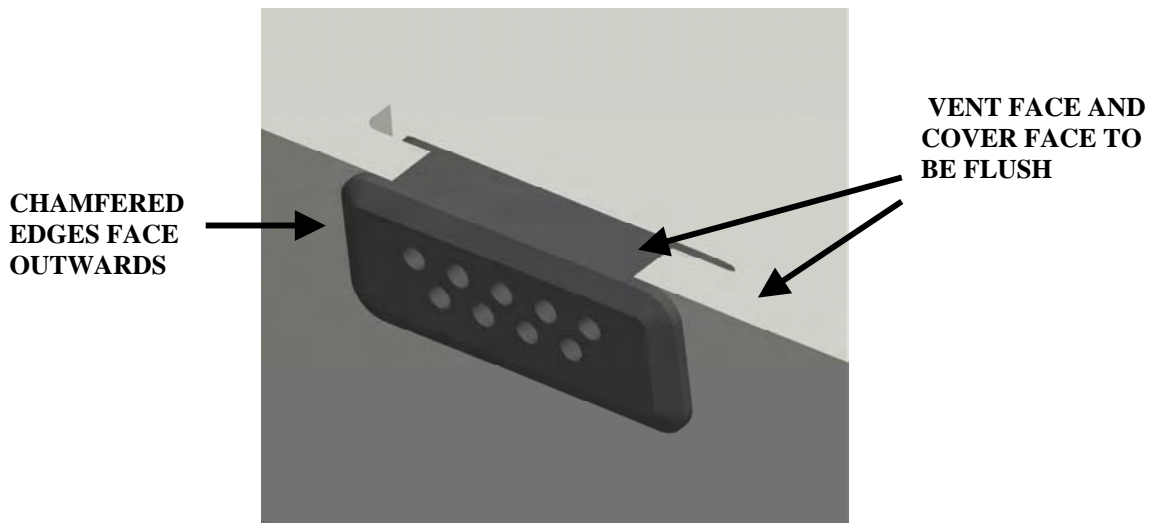

2. Replace the cover as described in the section **Refitting the Front Cover**.

Connecting the Optical Reading Head

The meter is provided with an optical reading port for use with the SonixCom PC program. The optical port can be used with either the front cover in position or removed.

To ensure correct communications it is essential that the optical probe is lined up as shown below. The lead must not be more than $\pm 15^\circ$ from the position shown as indicated below.

Note; The optical port is fixed and does not rotate to suit meter installation orientations.

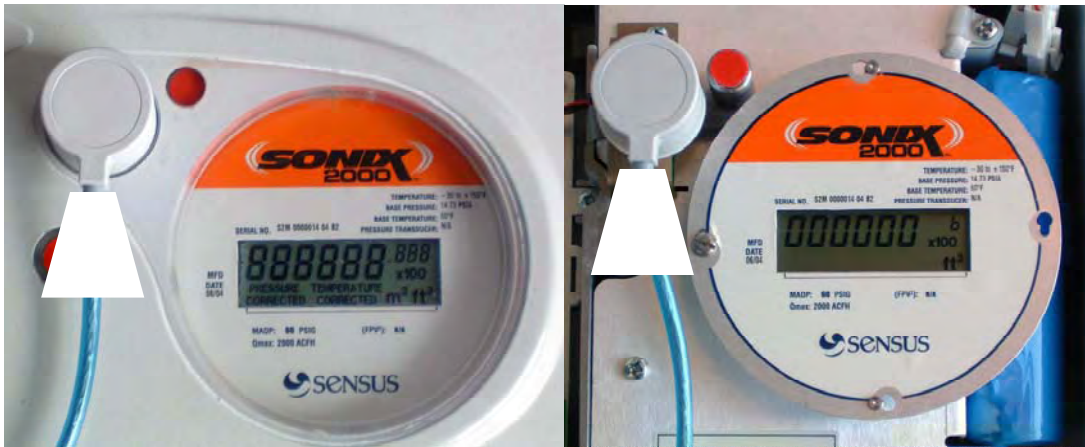

EEPROM Hardware Lock - Canadian Meters Only

Refer to the SonixCom manual supplied with the Sonixcom program for detailed instruction on locking and unlocking the EEPROM using software.

The EEPROM can be unlocked by changing the position of the switch located under the tamper obvious seal on the electronics cover.

1. If fitted use a flat blade screwdriver (or a Rockseal removal tool) to break the tamper obvious seal. The seal can then be pried out with the screwdriver blade.
2. Use flat bladed screwdriver (3/8" wide) to turn the lock switch 90 deg counter-clockwise to unlock the EEPROM.
3. The communications software can now be used to access the meter set up parameters.
4. Lock the EEPROM by turning the lock switch 90 deg clockwise. Replace the Rockseal.

Pulse Outputs

Refer to the SonixCom manual supplied with the Sonixcom program for detailed instruction.

Only, SUITABLE non-incendive inputs are to be connected to the field-wiring terminals via the PULSE cable.

Twin channel pulse outputs (Form A, 50 mS duration) are available on a field replaceable circuit board. The circuit board incorporates lightning protection and optical isolation from the main electronics.

Refer to the maintenance section for replacement of the pulse output board.

The twin pulse output channels can be configured in one of two output modes:-

- A. Uncorrected and Corrected Volume pulses
- B. Displayed Index and Alarm Pulses. (the displayed index depends on the status of temperature and pressure corrections modes in the meter)

In both cases it is possible to set the pulse volume scalar using the SonixCom application.

A shielded 4 wire cable should be passed through the one of the cable glands at the rear of the enclosure and secured with the P clip along side the pulse board.

The terminal blocks are marked for SIGNAL and GROUND connection. (note; ground connections are towards the center of the board in both cases).

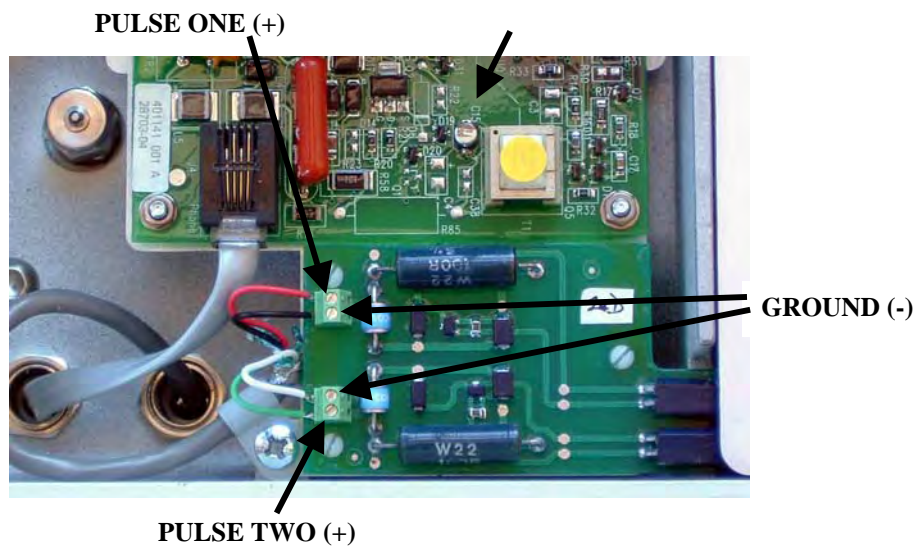

Pulse Output Options:
Option 1: Pulse 1: Uncorrected, Pulse 2: Corrected
Option 2: Pulse 1: LCD Index Volume, Pulse 2: Alarm

Maintenance

Battery Replacement

Old battery cartridges or modules should be disposed of properly based upon local regulations.

The main meter battery pack is located to the end of the electronics enclosure partly hidden by the display. The battery can be replaced (hot swapped) preventing a power down of the meter.

1. Remove the Cover as section **Removing the Front Cover**.
2. Locate the spare battery connector and plug in the replacement battery. Disconnect the old battery, and unhook the retaining strap located under the display. The battery can now be removed from the meter. It may be necessary to remove the LCD from it's mounting posts by removing the flat head screw and rotating the LCD assembly.



3. Slide the new battery into position under the display.
4. Secure the battery with the strap and tuck the connectors into the enclosure to ensure that wires will not get trapped when the cover is replaced. *Note; the strap is to stop the battery falling forward and does not have to be tight.*
5. Replace the cover as described in the section **Refitting the Front Cover**.
6. Use the battery change option on SonixCom to reset the battery life counters. It is recommended that this be done even if the power to the meter was not disconnected.

WARNING – EXPLOSION HAZARD – SUBSTITUTION OF COMPONENTS MAY IMPAIR SUITABILITY FOR CLASS 1, DIVISION 2.

AVERTISSEMENT – RISQUE D’EXPLOSION – LA SUBSTITUTION DE COMPOSANTS PEUT RENDRE CE MATERIEL INACCEPTABLE POUR LES EMPLACEMENTS DE CLASSE 1, DIVISION 2.

Replacing LCD

It is Possible to replace the LCD in service without removing the meter from its installation. The meter will need to be powered down and some data may be lost. Please contact Sensus Metering System's technical support group for advice on the requirement to replace the display.

The replacement LCD and its PCB is fragile and must be removed from its packaging and handled with extreme care.

1. Remove the cover as section **Removing the Front Cover**.
2. Disconnect the battery to power down the meter.
3. Remove the display securing screw. Rotate the display slightly to unlatch from the retaining posts. Turn the display over to expose the PCB.
4. Using a pair of cutters remove the cable tie, and disconnect the flat cable lead. The display sub-assembly can now be lifted clear of the meter.

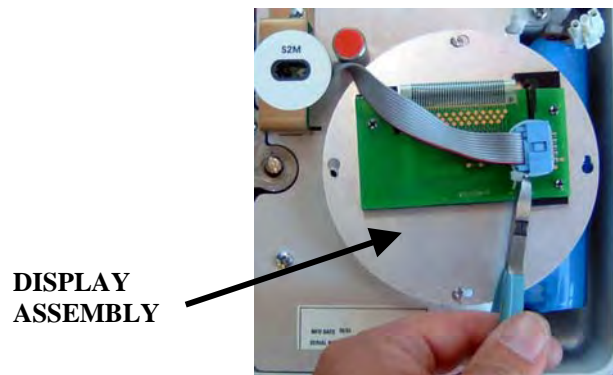

5. Using a flat bladed screwdriver gently pry the PCB off of the securing lugs and lift the board and LCD and support molding away from the index plate.

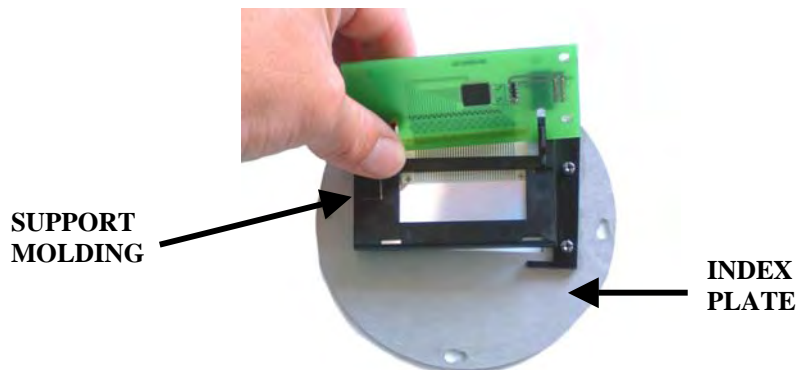

6. Lay the LCD/ PCB assembly down with the LCD facing up. Remove the LCD from the support molding by pressing down the latch tab and sliding the LCD out and away from the location lugs.

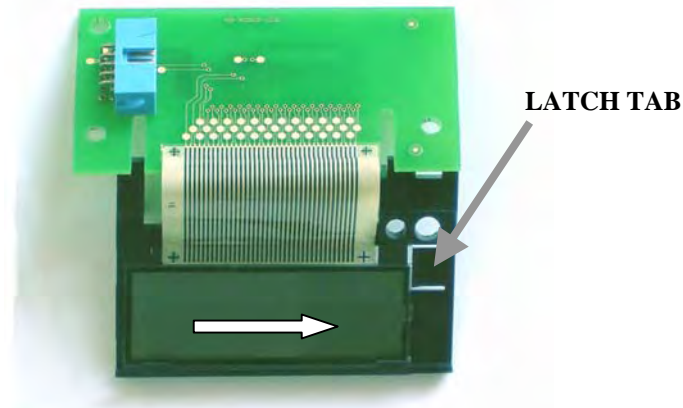

7. Fit the replacement LCD/PCB into the support molding as the reverse of removal above, taking **extreme care** not to damage the connection strip between the glass display and the board.
8. Position the support onto the back of the index plate and place the supplied foam pad into position over the lugs. Clip the board into position over the lugs on the index plate. *Note; If the board is loose the lugs can be tightened slightly by inserting a screwdriver blade into the lug slots.*
9. Replace the connector from the meter and secure with the cable tie supplied.
10. Replace the display and secure with the screw. Power up the meter by re-connecting the battery.
11. After a few moments the display should light up. Wait for all of the segments to light to check that the new display is functioning correctly.
12. Replace the cover as described in the section **Refitting the Front Cover**.

Clear the 'b' flag. **Refer to the SonixCom manual supplied with the Sonixcom program for detailed instruction.** .

Replacing the Pulse Board

It is Possible to replace the Pulse output board in service without removing the Meter from its installation. . Please contact Sensus Metering System's technical support group for advice on the requirement to replace the pulse output board.

1. Remove the cover as section **Removing and the Front Cover**.
2. Disconnect the leads from the terminal blocks on the pulse output board. Using a flat bladed screwdriver gently pry the pulse output board off of the 3 securing posts.
3. Pull the board out so that the connector to the main electronics is exposed. Unlatch the connector and remove the board.

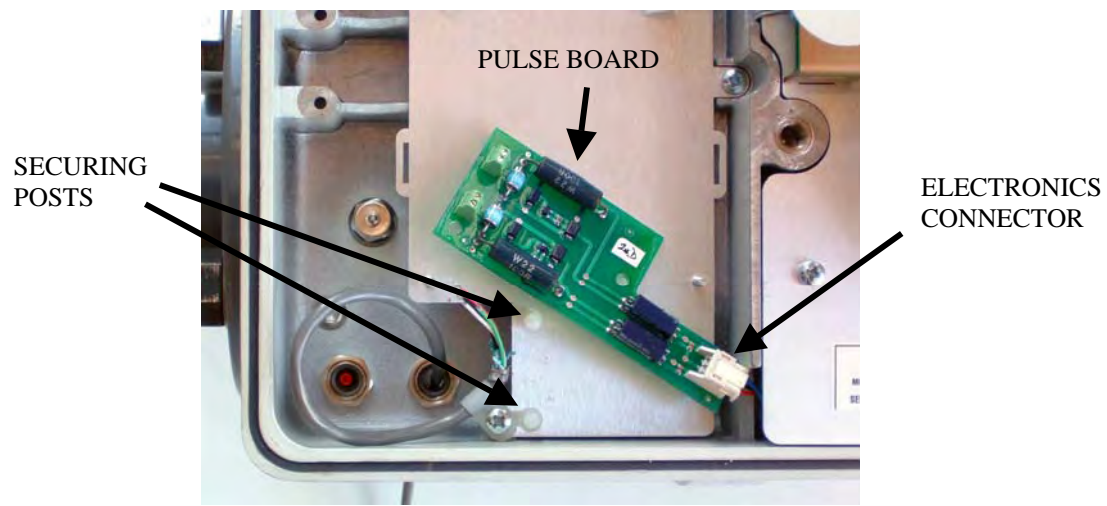

4. Fit the new board as the reverse of the above procedure. Ensure that the board is securely clipped into position.
5. Reconnect the wire connections, refer to the section **Pulse Outputs**.
6. Replace the cover as described in the section **Refitting the Front Cover**.