

Models 496 and 61R2

Domestic Service Regulator Installation and Maintenance Instructions

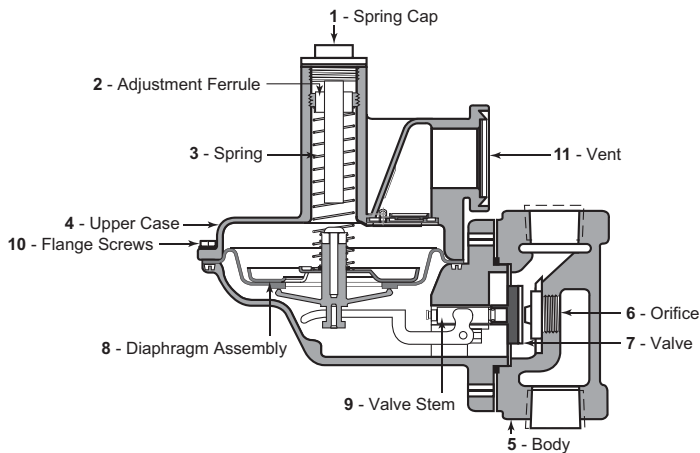

The Models 496 and 61R2 are general purpose gas pressure regulators for natural gas, air, CO₂, propane, butane, nitrogen, and other gases. They can be used for gas services to homes, commercial establishments and small industries as well as burners, unit heaters, boilers, and other equipment. All regulators include an internal relief valve.

can be rotated in 90° increments. The 61R2 can be rotated in any angle increment.

To rotate the 496 diaphragm case, detach the diaphragm case from the body by removing the two body-to-diaphragm case screws. After repositioning the diaphragm case to the desired position, reinstall the body-to-diaphragm case screws. For the Model 61R2, the diaphragm case can be rotated on the body without removing the body-to-diaphragm case screws. Simply loosen the two body-to-diaphragm case screws and retighten when the diaphragm case is in the desired position. For both models, ensure that the body-to-diaphragm screws are sufficiently tightened to reseal the regulator. 35-50 ft-lbs. of torque is recommended. The diaphragm case vent (11) should be positioned to minimize the chances of moisture collecting on the vent side of the diaphragm. The upper diaphragm case (4) may be rotated to a downward position by removing the flange screws (10).

The diaphragm case vent must be positioned to protect against flooding, rain, ice formation, traffic, tampering, etc. The vent must be protected against nest building animals, bees, insects, etc. to prevent vent blockage and minimize the chances for foreign material from collecting in the vent side of the regulator diaphragm. If required, the upper diaphragm case may be rotated by removing the upper-to-lower case flange screws and rotating the upper diaphragm case to the desired position. Reinstall the diaphragm flange screws and tighten to hold the diaphragm case in position and reseal, ensuring proper seal and verifying no leaks by using a soap and water solution or other utility-approved method.



Warning

Only qualified personnel should install or service a regulator. Regulators should be installed, operated, and maintained in accordance with applicable codes and regulations, and Sensus instructions.

If the regulator vents fluid or a leak develops in the system, it indicates that service is required. Failure to take the regulator out of service immediately may create a hazardous condition. Personal injury, equipment damage, or leakage due to escaping fluid or bursting of pressure-containing parts may result if this regulator is over pressured or is installed where service conditions could exceed published specification limits, or where conditions exceed any ratings of the adjacent piping or piping connections.

To avoid such injury or damage, provide pressure-relieving or pressure-limiting devices (as required by the appropriate code, regulation, or standard) to prevent service conditions from exceeding limits.

Additionally, physical damage to the regulator could result in personal injury and property damage due to escaping fluid. To avoid such injury and damage, install the regulator in a safe location.

Installation and Start-Up

1. Remove the shipping plugs from both the regulator inlet and outlet connections.
2. Make certain that the inside of the piping and the regulator inlet and outlet connections are clean. The connections must be free of dirt, pipe dope and other debris.
3. Use pipe joint material only on the male threads of the pipe being connected to the regulator. Do not use pipe joint material on the female threads of the regulator.
4. Install the regulator in the piping. Make certain that the gas flow through the regulator is in the direction as indicated by the arrow on the regulator body.

The regulators may be installed in any position: right side up, upside down, vertical piping, diagonal piping, etc.,. If required the diaphragm case may be rotated 360°. The Model 496



Caution

Do not overload the diaphragm with a sudden surge of inlet pressure. Turn the gas on very slowly. If an outlet stop is used, it should be opened first. Monitor the outlet pressure during start-up to prevent an outlet pressure overload.

5. Turn the gas on very slowly.
6. Make certain that all connections are tight, ensure proper seal and verify no leaks by using a soap and water solution or other utility-approved method.
7. If necessary, adjust outlet pressure (set point) by removing cap (1) and turning adjustment spring button (2). Turn clockwise to increase and counter-clockwise to decrease outlet pressure. Only adjust when gas is flowing through regulator. Be sure to reinstall cap.

Models 496 and 61R2

Domestic Service Regulator Installation and Maintenance Instructions



Caution

It is the user's responsibility to assure that all regulator vents and/or vent lines exhaust to a non-hazardous location away from ANY POTENTIAL sources of ignition. Where vent lines are used, it is the user's responsibility to assure that each regulator is individually vented and that common vent lines ARE NOT used.

8. The vent connection is an escape path for the regulated gas. Depending upon the type of gas, it could be flammable as with natural gas and propane. Therefore, the vent connection needs to be located and/or piped so that potential discharge occurs in a safe area away from buildings, open flames, collection areas, arcing devices, etc.

Regulators that are installed indoors or in a non-vented area must be vented to the outside. Run vent piping from the regulator vent connection to a non-hazardous location on the outside away from any potential sources of ignition. Since the Models 496 and 61R2 regulator are equipped with internal relief valves (IRV), the vent piping must be vent connection size or larger and its length be as short and direct as possible to a safe area. This is to assure the venting of the internal relief valve discharge to the atmosphere without excessive pressure increase in the regulator and downstream piping.

The outlet of the vent piping must allow for free and unobstructed passage of air and gas and must be protected against the potentials listed in instructions #4, #8 and #9.

9. For outdoor installations, it is recommended that the regulator be installed so that the regulator vent faces downward to avoid the potential for water and other foreign matter entering the regulator and interfering with the proper operation of the regulator.



Caution

Regulators are pressure control devices with numerous moving parts subject to wear that is independent upon particular operating conditions. To assure continuous satisfactory operation, a periodic inspection schedule must be adhered with the frequency of inspection determined by the severity of service and applicable laws and regulations.

Servicing

1. To access valve (7), orifice (6), or diaphragm assembly (8), first remove spring compression by unscrewing the spring cap (1) and spring adjustment ferrule (2). Remove spring (3) from regulator.
2. For access to the valve (7) and orifice (6), remove body-to-diaphragm case screws from body (5) with a 1/2" standard socket (or standard screwdriver for the 496) and remove diaphragm case assembly from body (5). For the 61R2, the screws release a collar bracket, which attaches the diaphragm case to the body.

3. To replace valve pad (7), simply pull off of valve stem (9) and replace with new pad.
4. To replace orifice (6), unscrew from body using a 7/8" hex socket wrench. Apply sealant on threads of orifice when installing replacement orifice. The replacement orifice must be installed at 50-60 ft-lbs. of torque.
5. To replace diaphragm assembly, remove flange screws (10) and disassemble diaphragm assembly. Make certain all parts are reassembled in their correct order and all threads and joints are tightened evenly and firmly.
6. Before reassembling body to diaphragm case, make certain that the 61R2 gasket/496 o-ring is in position. Ensure proper seal and verify no leaks by using a soap and water solution or other utility-approved method..

Over Pressurization Protection

Protection must be provided for the downstream piping system and the regulator's low pressure chambers to assure against the potential for over pressurization due to a regulator malfunction or a failure of the regulator to lock up. The allowable over-pressurization is the lowest of the maximum pressures permitted by federal codes, state codes, Sensus Bulletin RDS-1498, or other applicable standards. The methods of providing over-pressure protection could be a relief valve, a monitor regulator, a shut-off valve device or similar device.

Buried Service

The Models 496 and 61R2 regulators are not recommended for buried service.

Temperature Limits

The Models 496 and 61R2 regulators can be used for the flowing temperature of -20° F to 150° F (-28.9° C to 65.5° C).

Maximum Emergency Pressures

The maximum pressure the regulator inlet may be subjected under abnormal conditions without causing damage to the regulator is: Maximum Inlet Pressure plus 50 psi.

The maximum pressure to which the regulators case may be subjected under abnormal conditions without causing damage to the internal parts of the regulator is: Set point plus 3 psi. If the outlet pressure exceeds this pressure, the regulator must be removed from service and carefully inspected. Damaged or otherwise unsatisfactory parts must be replaced before returning the regulator to service.

The maximum outlet pressure that can be safely contained in the diaphragm case is 10 psi (safely contained means no leakage as well as no bursting.)

All products purchased and services performed are subject to Sensus' terms of sale, available at either; <http://na.sensus.com/TC/TermsConditions.pdf> or 1-800-METER-IT. Sensus reserves the right to modify these terms and conditions in its own discretion without notice to the customer.

This document is for informational purposes only, and SENSUS MAKES NO EXPRESS WARRANTIES IN THIS DOCUMENT. FURTHERMORE, THERE ARE NO IMPLIED WARRANTIES, INCLUDING WITHOUT LIMITATION, WARRANTIES AS TO FITNESS FOR A PARTICULAR PURPOSE AND MERCHANTABILITY. ANY USE OF THE PRODUCTS THAT IS NOT SPECIFICALLY PERMITTED HEREIN IS PROHIBITED.